

Diagnostic Procedure for Subaru Select Monitor Communication

CONTINUOUSLY VARIABLE TRANSMISSION (DIAGNOSTICS)

15. Diagnostic Procedure for Subaru Select Monitor Communication

A: COMMUNICATION FOR INITIALIZING IMPOSSIBLE

DIAGNOSIS:

Defective harness connector

TROUBLE SYMPTOM:

Subaru Select Monitor communication failure

WIRING DIAGRAM:

CVT control system <Ref. to WI-148, CVT Control System.>

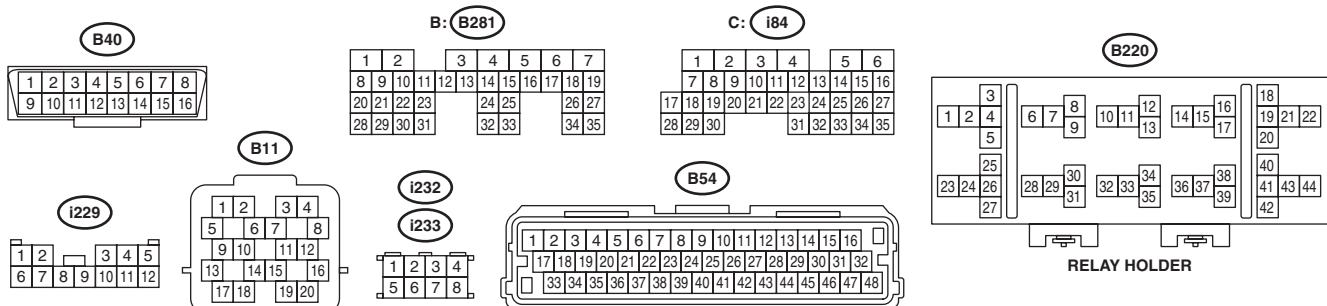
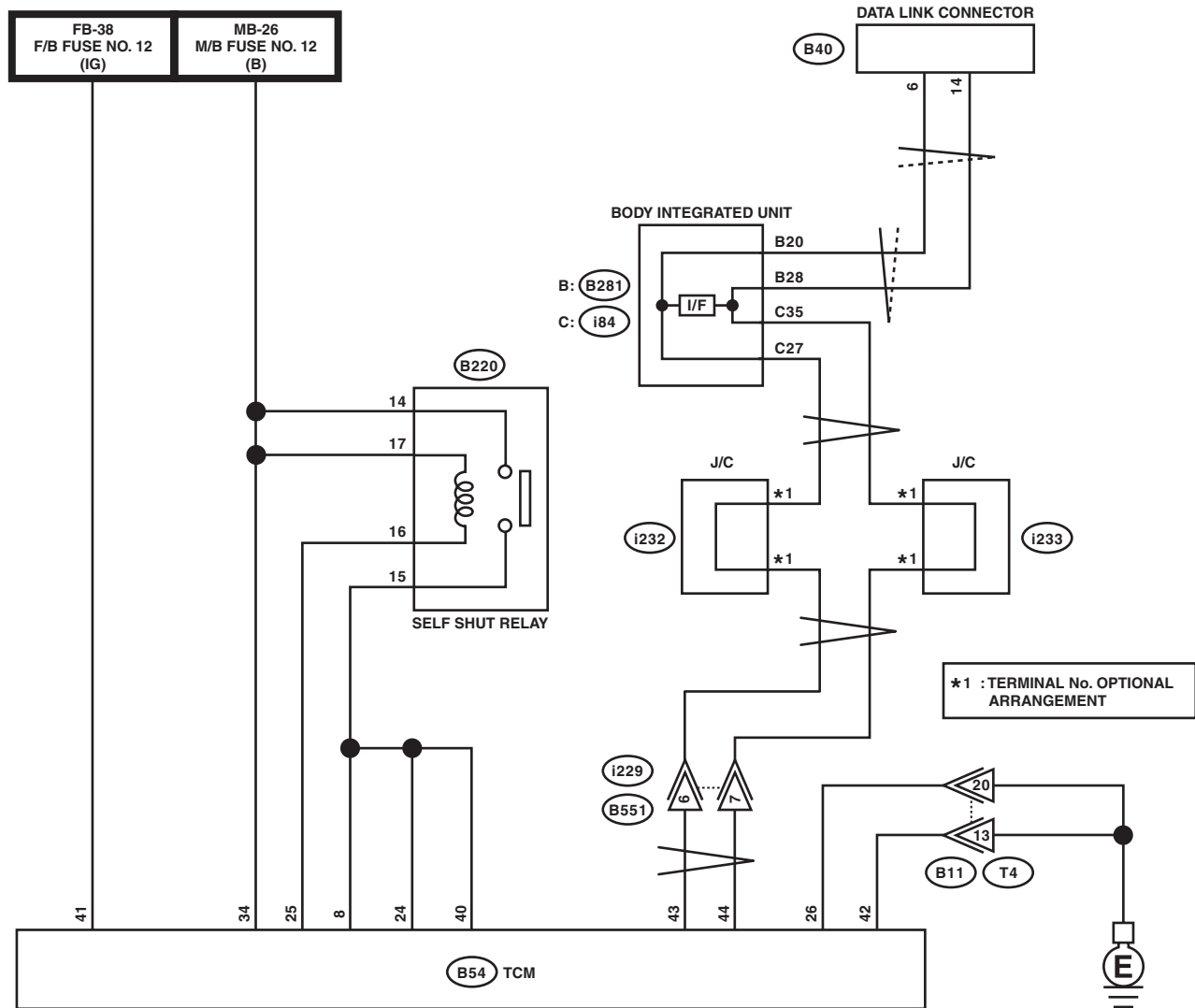

CVT00517

Diagnostic Procedure for Subaru Select Monitor Communication

CONTINUOUSLY VARIABLE TRANSMISSION (DIAGNOSTICS)

	Step	Check	Yes	No
1	CHECK IGNITION SWITCH.	Is the ignition switch ON?	Go to step 2.	Turn the ignition switch to ON, and select the transmission mode using the Subaru Select Monitor.
2	CHECK BATTERY. 1) Turn the ignition switch to OFF. 2) Measure the battery voltage.	Is the voltage 11 V or more?	Go to step 3.	Charge or replace the battery.
3	CHECK BATTERY TERMINAL.	Is there poor contact at battery terminal?	Repair or tighten the battery terminal.	Go to step 4.
4	CHECK INSTALLATION OF TCM CONNECTOR. Turn the ignition switch to OFF.	Is the TCM connector inserted into the TCM until the clamp locks?	Go to step 5.	Insert the TCM connector to TCM.
5	CHECK LAN SYSTEM. Perform the diagnosis for LAN system. <Ref. to LAN(diag)-2, Basic Diagnostic Procedure.>	Is there any fault in LAN system?	Perform the diagnosis according to DTC for LAN system. <Ref. to LAN(diag)-70, List of Diagnostic Trouble Code (DTC).>	Go to step 6.
6	CHECK SUBARU SELECT MONITOR COMMUNICATION. 1) Turn the ignition switch to ON. 2) Check whether communication to transmission system can be executed normally.	Is the system name displayed on Subaru Select Monitor?	Check DTC of TCM. <Ref. to CVT(diag)-16, Read Diagnostic Trouble Code (DTC).>	Go to step 7.
7	CHECK POWER SUPPLY CIRCUIT. 1) Turn the ignition switch to ON. (engine OFF) 2) Measure the ignition power supply voltage between TCM connector and chassis ground. Connector & terminal (B54) No. 8 (+) — Chassis ground (-): (B54) No. 24 (+) — Chassis ground (-): (B54) No. 34 (+) — Chassis ground (-): (B54) No. 40 (+) — Chassis ground (-): (B54) No. 41 (+) — Chassis ground (-):	Is the voltage 10 — 13 V?	Go to step 8.	Repair the open circuit of harness between TCM and battery.
8	CHECK HARNESS CONNECTOR BETWEEN TCM AND CHASSIS GROUND. 1) Turn the ignition switch to OFF. 2) Disconnect the connector from TCM. 3) Measure the resistance of harness between TCM connector and chassis ground. Connector & terminal (B54) No. 26 — Chassis ground: (B54) No. 42 — Chassis ground:	Is the resistance less than 10 Ω?	Go to step 9.	Repair the open circuit of the TCM ground circuit and poor contact of connector.
9	CHECK POOR CONTACT OF CONNECTOR.	Is there poor contact of control module power supply, ground circuit and data link connector?	Repair the connector.	Replace the TCM. <Ref. to CVT(TR690)-126, Transmission Control Module (TCM).>